

Door Node Board Installation Sheet



We reserve the right to alter, without giving prior notice, technical data, dimensions and weights described in this manual

LiftStore Limited Manor Farm Industrial Estate, Flint, Flintshire CH6 5UY Tel: 01352 793222 Fax: 01352 793255

Door Node
TVL 321 ISSUE 1

Precautions

The board must be mounted in suitable protective box or car operating panel. Observe normal precautions for handling electronic devices, avoid static electricity dampness and extreme temperatures. Please read this instruction sheet fully before use.

Specification

Supply Voltage	20 to 24 V d.c.
Board Operating Current	40mA
Max Input Voltage (F11-8)	24V d.c.
Max Output Current Feature Outputs (FO1-4, per output)	5A @ 24V d.c. / 5A @ 240V a.c.
Input Short Circuit Protection	Yes
Dimensions (without DIN carrier)	110 x 72 x 40mm
Fixings	6 x M3 at 100mm centres
Dimensions (with DIN carrier)	115 x 85 x 65mm

DIP Settings

SW1



DIP	Name	DIP 3 to set side
4	Test Mode	OFF = Front
3	Side	ON = Rear
2	Spare	
1	Spare	DIP 4 for test mode (normally off)

SW3



DIP	Name	DIPs 1 and 2 on for CAN termination
2	CAN Term	These should be set on the last node in the network only.
1	CAN Term	

Jumper Settings

SW2 Place Jumper in the 1-2 position for normal operation.

Loop and Fault LED's

The Green LED (D4) will flash every 2 seconds to signify power to node and that the node is running.

The Red LED (D6) will light continuously for 4 seconds when the node is first powered up. After this point the red LED signifies various fault codes. The LED will do a quick flash every 4 seconds if the node has a fault.

- 1 flash every 4 secs = Node not communicating with Ethos.
- 2 flashes every 4secs = Node is experiencing data bus faults.
- 3 flashes every 4 secs = Node has stopped transmitting due to bus faults.
- 4 flashes every 4 secs = Node has stopped transmitting or receiving from the data bus

Typical Wiring and Dimensions of Door Node

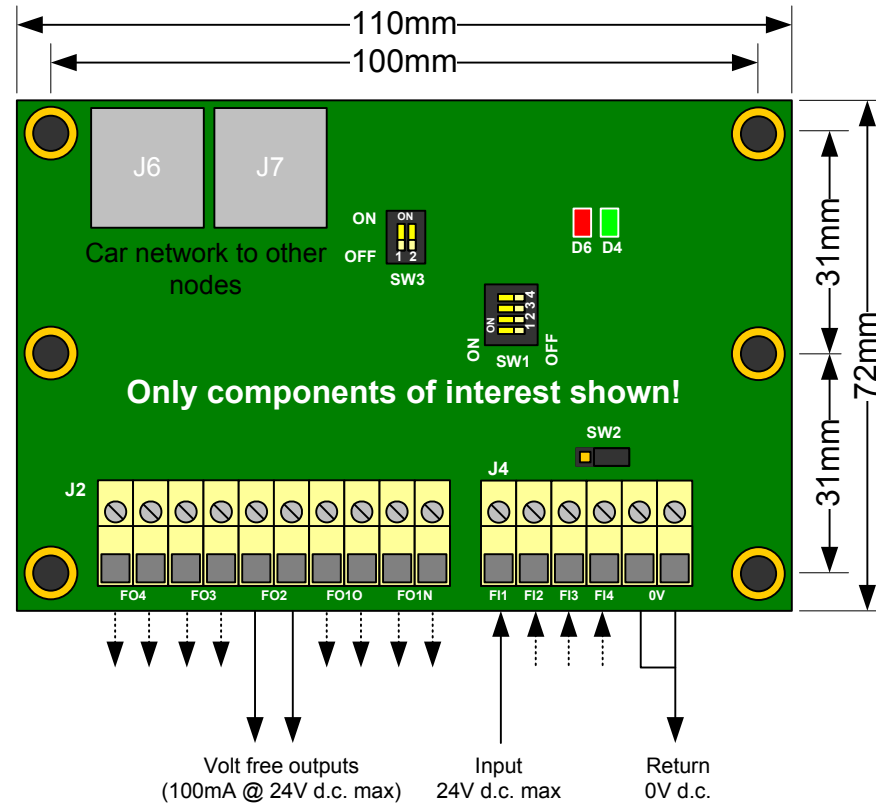

Typical Network Setup

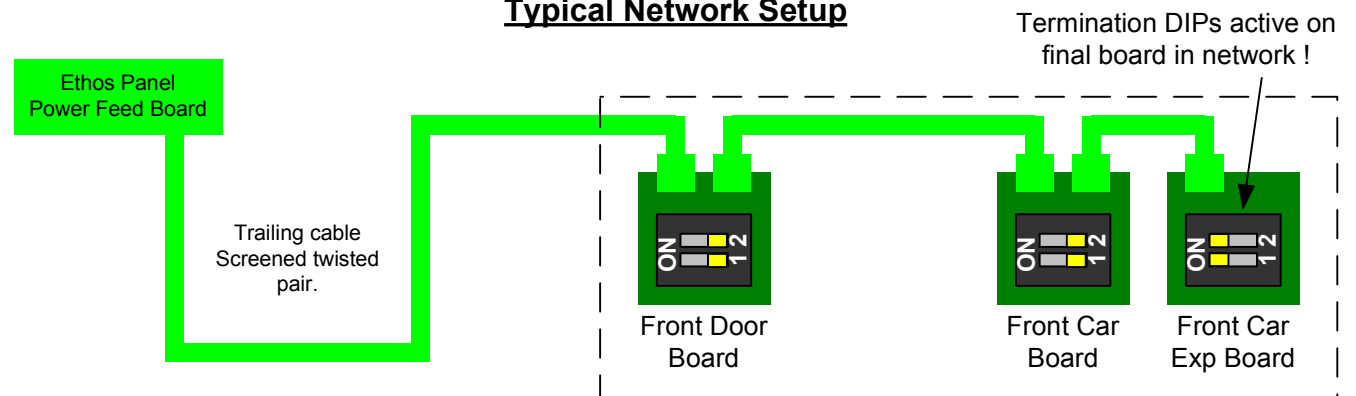

INTRODUCTION

This Manual is to be read in conjunction with Ethos Operation Manual (TVL273) It is important that you familiarise yourself with both manuals before commencing any work with the Ethos or the Ethos Serial system. Be aware that the lift panel will contain equipment that is supplied with potentially lethal voltages. Please make sure the panel is isolated before carrying out any installation work or modifications. The Liftstore Ethos Serial System is a distributed field-bus network for interfacing calls and I/O to an Ethos lift controller. The system is used in place of normal discrete wiring for calls and car related input and outputs. Instead of each push and call lamp being directly connected to the panel, in the motor room, they are connected to local PCB's or nodes that are distributed about the lift shaft and car.

BASIC SETUP GUIDE

This basic guide is designed to give an outline of installation and set up of a Ethos serial system. Please refer to relevant installation sheets for more in depth information.

Lift Shaft

Mount Landing Nodes in the shaft, either in the push back boxes or in a suitable plastic box mounted close to the push station.

Each Landing node has a unique ID this should be set as per the controller drawings, make sure the nodes are installed at the correct landings.

Connect Landing pushes and acceptance lamps to nodes, make sure wiring is correct 3-wire system.

Connect each landing node to the next one in the shaft, using the supplied patch cables.

Connect terminator boards, if applicable, to the ends of the landing networks. Warning: a maximum of 2 terminators should be fitted to this network in total.

Connect landing node network back to the Power Feed Board on the Ethos controller.

Lift Car

The car related boards may be mounted in the car push station or in the terminal box on the car top.

Wire in all car pushes and acceptance lamps plus optional features inputs and outputs as per wiring diagrams.

Configure car board for front or rear operation, then do the same with the door board and car expansion boards. These settings are shown on the controller diagrams.

Connect all nodes together with supplied patch cables, as per the drawings. The final board in the chain should have its network termination DIP's switched on, again make sure these are only active on one node on the car.

Plug the first board on the car top into the relevant trailer connections.

The screens from the trailer cores must be earthed at the panel end of the trailer only, as per the diagrams.

Machine Room

Install main panel. Make sure the routing of any mains or motor cables are kept away from the network cables.

Connect up shaft network to the Power feed board and then if applicable connect this to the other controllers in the group.

Connect the car network from the trailer to power feed board. Make sure screens from the trailer are earthed.

Once wiring has been completed and checked follow the standard Ethos power up routine.

Make sure all nodes are present in the Node monitor screens of the MMI. All nodes can be tested by activating inputs or call pushes and seeing the result appear on the MMI monitor screens.

EMC GUIDELINES

It is extremely important that the following guidelines are adhered to.

All bus runs must be kept away from motor wiring, a separation of at least 300mm.

Keep bus wiring away from mains.

If wiring has to cross any high voltage cable this must be done at right angles.

Nodes must be mounted away from any high voltage equipment e.g. motors, door gear etc.

Mains power input and motor output cables should be shielded and earthed as per panel drawings.

Any screens in the trailing cable must be earthed at the panel end only.

Networks must be correctly terminated, with termination board on the landing network and with termination DIP's on the last car board in the system.

FAULT FINDING PROCEDURES

Fault Finding Within a System

With power applied to the system check that all nodes have their green LED's flashing. If the green LED's are not flashing check the power supply on the power feed board.

Check current events in the Ethos for any relevant problems

A network failing to respond on power up would be caused by :

Incorrect or broken wiring connection on the network.

No nodes connected to the network.

One or both of the network power supplies not working or connected.

None of the nodes configured correctly.

If a network has failed to respond to commands sent out by the Ethos then repeated tries will be made to establish communication. When the network connection is established this is also reported as an event in the Ethos event log.

System checks

After testing an installation as described above and having no response to calls placed in the system the following need to be checked:

That the panel is on normal mode.

The DIL switches are set correctly on all boards and termination boards and termination DIL switches are fitted where necessary.

All network connections are connected to the correct terminals.

Both networks are connected to the panel connections.

The car and landing networks are not swapped over.

Check that the green LEDs' on both Car and Landing nodes are flashing

Check nodes for red fault LED's. see relevant board installation sheet for description.

If the green LEDs' fail to illuminate then the 24 volt supply is not connected to the node

Check external feeds to the car boards

If all of the above are correct then the networks should function correctly.