

pushbuttons

compact 2 bar



Compact 2 Bar Button

The Compact 2 Bar Button has been designed as an extra long button and is ideal for use as a main floor button, where its extra size helps users to quickly identify that floor.

The Compact 2 Bar Button matches our circular ranges (US91, US91-15 and US95) but can also be used in conjunction with all our ranges. The design of the button is based on the standard Compact 2, so you can be sure of its long life, durability and vandal resistance.

key features

- Extra long button
- Legend and halo illumination (single/dual)
- Vandal resistant

Dewhurst plc
Inverness Road
Hounslow
Middlesex TW3 3LT UK

Tel: +44(0) 20 8607 7300
Fax: +44(0) 20 8572 5986
Email: info@dewhurst.co.uk
www.dewhurst.co.uk

specification

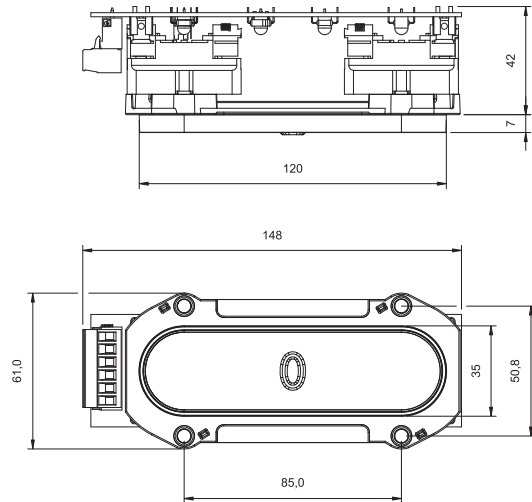

This product is designed to meet the requirements of the following codes and regulations either in its standard form or through variants.

EN81-1/2	✓
BS8300	✓
M2/S2	✓
EN81-70	✓
B44	✓
EN81-71	Category 2
AS1735.12	✓
EN81-72	✓
A117.1	✓
EN81-73	✓
EN60529	IP44

technicals

- Moulded in high grade polycarbonate
- LED current 40mA
- 1 n/o contact as standard
- A detailed data sheet for this product can be found on our website
- UL/CSA approved

benefits

- Standard proven design
- Low profile, only 43mm deep
- Vandal resistant

options

- Dual illumination
- Range of pressel finishes

For more information on our compact 2 range contact us at:

Dewhurst plc
Inverness Road
Hounslow
Middlesex TW3 3LT UK

Tel: +44(0) 20 8607 7300
Fax: +44(0) 20 8572 5986
Email: info@dewhurst.co.uk

www.dewhurst.co.uk